

FLIGHT OPERATIONS

Operating Manual Supplement

**Supplement Number G500-OMS-1:
G500 Evacuation Crewmember Training Requirements**

**Revision 2
November 20, 2008**

**Type: Abnormal Procedures
Production Effectivity: All G500 Airplanes**

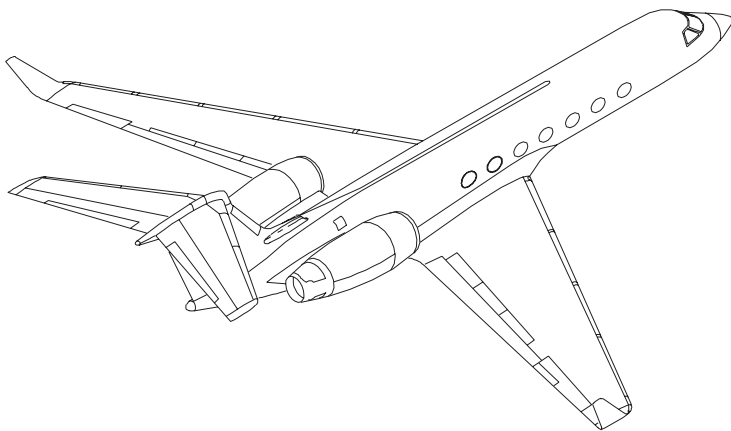

Gulfstream

© 2008 Gulfstream Aerospace Corporation

All rights reserved, including the right to reproduce this publication. No part may be reproduced, stored in any retrieval system, or transmitted in any part or form or by any means, electronic, photo-copying, microfilm, microfiche, mechanical, or otherwise, without prior written permission of Gulfstream Aerospace Corporation.

Gulfstream G500

OPERATING MANUAL SUPPLEMENT

G500-OMS-01

LOG OF REVISIONS

Rev. No.	Pages Revised	Description of Revision	Date
2	1	Revised GER effectivity.	Nov 20/08
2	4	Revised Ditching text to provide an egress option through the Main Entry Door when the elliptical window exit is not an option.	Nov 20/08
2	16	Revised Prepare Cabin text regarding placement and use of flashlights (2 places). Revised Prepare Cabin text regarding placement of dogs (1 place).	Nov 20/08
2	31	Revised Procedures If You Are Incapacitated text regarding passenger directions and sample instructor's notes.	Nov 20/08

Gulfstream G500

OPERATING MANUAL SUPPLEMENT

G500-OMS-01

This page intentionally left blank.

Gulfstream G500

OPERATING MANUAL SUPPLEMENT

G500-OMS-01

LIST OF EFFECTIVE PAGES

<u>SECTION</u>	<u>PAGE</u>	<u>REV</u>	<u>DATE</u>
Front Matter	1	2	Nov 20/08
Front Matter	2	2	Nov 20/08
Front Matter	3	2	Nov 20/08
Front Matter	4	2	Nov 20/08
Front Matter	5	2	Nov 20/08
Front Matter	6	2	Nov 20/08
G500-OMS-01	1	2	Nov 20/08
G500-OMS-01	2	2	Nov 20/08
G500-OMS-01	3	2	Nov 20/08
G500-OMS-01	4	2	Nov 20/08
G500-OMS-01	5	2	Nov 20/08
G500-OMS-01	6	2	Nov 20/08
G500-OMS-01	7	2	Nov 20/08
G500-OMS-01	8	2	Nov 20/08
G500-OMS-01	9	2	Nov 20/08
G500-OMS-01	10	2	Nov 20/08
G500-OMS-01	11	2	Nov 20/08
G500-OMS-01	12	2	Nov 20/08
G500-OMS-01	13	2	Nov 20/08
G500-OMS-01	14	2	Nov 20/08
G500-OMS-01	15	2	Nov 20/08
G500-OMS-01	16	2	Nov 20/08
G500-OMS-01	17	2	Nov 20/08
G500-OMS-01	18	2	Nov 20/08
G500-OMS-01	19	2	Nov 20/08
G500-OMS-01	20	2	Nov 20/08
G500-OMS-01	21	2	Nov 20/08
G500-OMS-01	22	2	Nov 20/08
G500-OMS-01	23	2	Nov 20/08
G500-OMS-01	24	2	Nov 20/08

Gulfstream G500

OPERATING MANUAL SUPPLEMENT

G500-OMS-01

<u>SECTION</u>	<u>PAGE</u>	<u>REV</u>	<u>DATE</u>
G500-OMS-01	25	2	Nov 20/08
G500-OMS-01	26	2	Nov 20/08
G500-OMS-01	27	2	Nov 20/08
G500-OMS-01	28	2	Nov 20/08
G500-OMS-01	29	2	Nov 20/08
G500-OMS-01	30	2	Nov 20/08
G500-OMS-01	31	2	Nov 20/08
G500-OMS-01	32	2	Nov 20/08
G500-OMS-01	33	2	Nov 20/08
G500-OMS-01	34	2	Nov 20/08
G500-OMS-01	35	2	Nov 20/08
G500-OMS-01	36	2	Nov 20/08
G500-OMS-01	37	2	Nov 20/08
G500-OMS-01	38	2	Nov 20/08
G500-OMS-01	39	2	Nov 20/08
G500-OMS-01	40	2	Nov 20/08
G500-OMS-01	41	2	Nov 20/08
G500-OMS-01	42	2	Nov 20/08
G500-OMS-01	43	2	Nov 20/08
G500-OMS-01	44	2	Nov 20/08
G500-OMS-01	45	2	Nov 20/08
G500-OMS-01	46	2	Nov 20/08
G500-OMS-01	47	2	Nov 20/08
G500-OMS-01	48	2	Nov 20/08

Gulfstream G500

OPERATING MANUAL SUPPLEMENT

G500-OMS-01

TABLE OF CONTENTS

<u>SUBJECT</u>	<u>PAGE</u>
GENERAL	1
Introduction	1
Source of Data	1
Applicability	1
EVACUATION CREWMEMBER TRAINING	2
General	2
Minimum Training	2
Testing Requirements	2
Training Requirements.....	3
Specific Interior Configuration Training.....	4
Passenger Flow	4
PASSENGER BRIEFING	5
General	5
Passenger Briefing Options	5
COMPLIANCE TO TRAINING REQUIREMENTS	6
Curriculum.....	6
Training	6
Evacuation Crewmember Recurrent Training.....	6
Record of Evacuation Crewmember Training.....	7
APPENDIX A: SAMPLE CURRICULUM OUTLINE	9
APPENDIX B: SAMPLE CLASSROOM TRAINING OUTLINE	10
APPENDIX C: EVACUATION CREWMEMBER EXAM	33
APPENDIX D: PASSENGER BRIEFING SCRIPT	37
APPENDIX E: TRAINING VERIFICATION	45

Gulfstream G500

OPERATING MANUAL SUPPLEMENT

G500-OMS-01

This page intentionally left blank.

GENERAL

Introduction

Certification requirements established by the regulatory authorities have mandated that an additional evacuation crewmember as well as a passenger briefing is required on the G500 aircraft for all flights with ten (10) or more passengers regardless of the type of operation.

This supplement is provided to establish clear operational and training requirements for the evacuation crewmember to the operator or the training organization responsible for meeting the training requirements. The operational and training requirements established in this document are not mandatory for any operations with nine (9) or fewer passengers.

Source of Data

The source of the data used in this supplement is the FAA-approved Gulfstream Engineering Report number GVSP-GER-6111, GV-SP Evacuation Crewmember Training Requirements, Revision C, dated November 19, 2008.

Applicability

This supplement is applicable to all G500 airplanes (GV-SP airplanes having Aircraft Service Change (ASC) 10).

Gulfstream G500

OPERATING MANUAL SUPPLEMENT

G500-OMS-01

EVACUATION CREWMEMBER TRAINING

General

NOTE: It is not required that the evacuation crewmember be trained in any other flight attendant functions other than those listed in this supplement.

1. A crewmember trained in evacuation is an additional required crewmember for all flights having 10 or more passengers.
2. The required pilot and co-pilot cannot serve this function.
3. The evacuation crewmember must be trained in the recommended methods for evacuating through the Gulfstream elliptical exits.
4. The evacuation crewmember must be trained in the procedures for directing passenger flow to the available exits to prevent someone who may not fit through, or may have other personal disabilities which may preclude them from using the elliptical exit, from blocking it so that others may utilize the exit.

Minimum Training

1. Initial and Recurrent Training Requirements

No operator may use a person, nor may any person serve as an evacuation crewmember unless that person has completed the initial or recurrent evacuation crewmember training since the beginning of the 12th calendar month before that service.

2. Recurrent Training

Each operator must ensure that each evacuation crewmember receives recurrent training and is adequately training and currently proficient for the type aircraft and crewmember position involved. See **Evacuation Crewmember Recurrent Training** section for detailed requirements for recurrent training.

Testing Requirements

No operator may use an evacuation crewmember, nor may any person serve as an evacuation crewmember unless since the beginning of the 12th calendar month before that service the operator has determined by appropriate initial or recurrent testing that the person is knowledgeable and competent in the following areas as appropriate to assigned duties and responsibilities:

1. Authority of the pilot in command.
2. Crewmember assignments, functions, and responsibilities during evacuation of persons who may need the assistance of another person to move expeditiously to an exit in an emergency.
3. Briefing of passengers (see **Passenger Briefing** section).
4. Location and operation of all normal and emergency exits and related equipment.
5. Seating of persons who may need assistance of another person to move rapidly to an exit in an emergency as prescribed by the operator's operations manual.
6. An understanding of the recommended, configuration specific, method for evacuating through the Gulfstream elliptical exits (see **Passenger Briefing** section) and procedures for directing passenger flow (see **Passenger Flow** section).

Training Requirements

1. Each training program must provide emergency training for each aircraft configuration (i.e., training for directing passenger flow and illustrate the recommended method for evacuating through the elliptical exits for the various interior configurations, see **Specific Interior Configuration Training, Passenger Flow** and **Passenger Briefing** sections) and each kind of operation conducted.
2. Emergency training must provide the following:
 - A. Instruction in emergency assignments and procedures, including coordination among crewmembers;
 - B. Individual instruction in the location, function, and operation of emergency equipment used in evacuation; and
 - C. Instruction in the handling of emergency situations including evacuation.
3. For initial and recurrent training, each evacuation crewmember must perform at least the following emergency drills using a representative Gulfstream aircraft or cabin mockup training device which has the Gulfstream elliptical exits installed:

Gulfstream G500

OPERATING MANUAL SUPPLEMENT

G500-OMS-01

- A. Ditching, if applicable; this includes opening and egressing through a representative Gulfstream main entry door when the elliptical exit is not usable or if you have a passenger(s) who is unable to use the elliptical exit. Conduct an emergency evacuation drill to demonstrate directing of passenger(s) flow out the main entry door (reference Section 2.4.2).
- B. Emergency evacuation. This includes opening and egressing through a representative Gulfstream elliptical exit and conduct of an emergency evacuation drill to demonstrate directing of passenger flow (reference Section 2.4.2).
- C. Operation and use of Gulfstream elliptical exits. Training must include personal experience in opening and egressing through an elliptical exit on either a representative Gulfstream aircraft or a cabin mockup training device that has the Gulfstream elliptical exits installed. (Note: The exit used for this egress exercise must latch the same, open the same, and be similar in weight to that of a G500 aircraft exit).

Specific Interior Configuration Training

Specific interior configuration training that provides the recommended methods for evacuating through the Gulfstream elliptical exits for the specific interior configuration(s) for which operation is desired (see **Passenger Briefing** section) must be provided (i.e., divan, credenza and single/club seating configurations).

Training for the specific interior configuration(s) may be provided through the use of a video-tape which would provide egress information similar to that provided in the **Passenger Briefing** section or by conducting an actual egress on an aircraft outfitted with that specific interior along with the other training required herein.

Passenger Flow

1. Initial Crewmember Training

The initial training curriculum must include conducting emergency evacuation drill(s) through a Gulfstream elliptical exit (i.e., one that latches the same, opens the same, and is similar in weight to the G500 exit).

Gulfstream G500

OPERATING MANUAL SUPPLEMENT

G500-OMS-01

This must be conducted with a minimum of five (5) “passengers” other than the trainee (crewmember training classmates may be used for this activity). At least one of these individuals must simulate or represent a person who does not fit through, or is otherwise incapable of utilizing, the Gulfstream elliptical exit. Training must be conducted on either a representative Gulfstream aircraft or a cabin mockup training device which has the Gulfstream elliptical exits installed.

2. Recurrent Crewmember Training

The recurrent training program must include a review of the above training, however may be limited to the individual being trained and include opening and removing the exit window and egress through the elliptical exit. This may be performed on either a representative Gulfstream aircraft or a cabin mockup training device which has the Gulfstream elliptical exits installed.

NOTE: This portion of the recurrent training is only required every 24 months.

PASSENGER BRIEFING

General

A pre-flight briefing on the configuration specific egress procedures and exits of the airplane must be provided to all passengers before each flight. This briefing may be verbal or video taped and must include a detailed explanation of the recommended method for evacuating through the Gulfstream elliptical exits, and must include specific information for egress from the aircraft configuration for which operation sought (representative of the actual interior configuration in front of the available exits).

Passenger Briefing Options

A passenger briefing Digital Video Disc (DVD) will be provided with the completed aircraft to each operator. As a backup, audible passenger briefing capabilities will be provided to each operator using the Airshow cabin display system. **Appendix D** of this report is the video script of the passenger briefing used on the G500. A copy of this script will be provided to each operator to use as a guide for verbal passenger briefings.

Gulfstream G500

OPERATING MANUAL SUPPLEMENT

G500-OMS-01

COMPLIANCE TO TRAINING REQUIREMENTS

Curriculum

Appendix A of this document provides a sample curriculum outline for crewmember evacuation requirements.

Training

Appendix B of this document is a sample class presentation along with Sample Instructor Notes for Crewmember Evacuation training. This session must include emergency situation drills including egress through the G500 elliptical exits.

Practical application of the classroom training is completed on a representative aircraft or cabin trainer as part of the training program.

- Actual exit removal
- Egress of the minimum number of individuals
- Handling of passengers incapable of using overwing exits

The content of this training program cannot be adjusted without previous approval from Gulfstream Aerospace and the FAA.

Evacuation Crewmember Recurrent Training

Each operator must ensure that each evacuation crewmember receives recurrent training and is adequately trained and currently proficient for the type aircraft and crewmember position involved.

To meet the recurrent ground training for evacuation crewmembers the crewmember must:

- Successfully complete a written examination/quiz (see **Appendix C**) to determine the crewmember's knowledge of the aircraft and crewmember position involved.

Gulfstream G500

OPERATING MANUAL SUPPLEMENT

G500-OMS-01

- View the Specific Interior Configuration Training video discussed in the **Specific Interior Configuration Training** section. As previously discussed a general egress Digital Video Disc (DVD) will be produced for each completed aircraft prior to customer delivery. This instructional video will demonstrate proper removal of the elliptical exits, operation of alternate Type I exits and proper egress procedures for the G500 aircraft.
- Every 24 months the evacuation crewmember must successfully accomplish the emergency drills related to egress and appropriate to the recurrent training as specified in the **Passenger Flow** section.

Record of Evacuation Crewmember Training

Each G500 operator must maintain a record of emergency crewmember training for each person that has successfully completed the required training. **Appendix E** of this document is an evacuation crewmember training sign-off sheet that can be used for this purpose.

Gulfstream G500

OPERATING MANUAL SUPPLEMENT

G500-OMS-01

This page intentionally left blank.

APPENDIX A
SAMPLE CURRICULUM OUTLINE

Classroom Training

1. Preparation
 - A. CRM
 - B. Preflight Crew Briefing
2. Error Management
3. Anticipated Emergencies
 - A. Obtain Information
 - B. Emergency Checklist
 - C. Prepare Cabin
 - D. Brace Positions
 - E. Special Needs Passengers
 - F. Secure Cabin and Galley
 - G. Personal Preparation
 - H. Final Preparation
4. Unanticipated Emergencies
 - A. Possible Scenarios
 - B. Unplanned Emergency Commands
 - C. Turbulence
5. Evacuation
 - A. Commands
 - B. Evacuation
 - C. Final Procedures
6. Review

On-Aircraft or Cabin Mockup Training

1. Hands-on Training
 - A. Practical Application of Above Classroom Material
Must include the appropriate training covered in the **Training Requirements** section.

Gulfstream G500

OPERATING MANUAL SUPPLEMENT

G500-OMS-01

APPENDIX B

SAMPLE CLASSROOM TRAINING OUTLINE

Sample Class Presentation Slide:

Objectives

- Describe the basic principles of evacuation
- Describe the signals and appropriate procedures for conducting the evacuation
- Review exits, procedures and commands to be used in an emergency

Sample Instructor's Notes:

As stated above.

Sample Class Presentation Slide:

Preparation Before Any Trip

- CRM and communication is crucially important in emergency situations
- Preflight Crew Briefing
- Preflight the emergency equipment
- Know your A/C Configuration (all available exits)
- Perform the Passenger Safety Briefing
- Silent Review during every takeoff

Sample Instructor's Notes:

These are some items that you can use to prepare yourself, your crew and your passengers prior to departure.

Remember that you could very well have an emergency during take off, and these items may be the only time you have to prepare.

Sample Class Presentation Slide:

The Goal Of CRM

“To prevent aviation accidents by improving crew performance through better crew coordination.”

- 60-80% of all aviation accidents are attributed to crew error
- This statistic can be greatly reduced through the use of CRM

Sample Instructor’s Notes:

As stated in slide

Sample Class Presentation Slide:

Crew Briefing

The crew briefing is the beginning of any safe flight and good CRM

- Sets the tone for the trip
- Establishes expectations and contingency plans
- Enhances situational awareness
- Identifies key elements for safety

Sample Instructor’s Notes:

The importance of the preflight crew briefing.

Gulfstream G500

OPERATING MANUAL SUPPLEMENT

G500-OMS-01

Sample Class Presentation Slide:

Preflight Crew Briefing

Prior to each scheduled departure, the PIC should give a preflight crew briefing, which should include:

- General weather conditions enroute
- Anticipated ATC delays or hold procedures in effect
- Recommendations or instructions as to the conduct of cabin service relative to the weather conditions anticipated
- Assigned emergency exit (overwing windows unless otherwise specified)
- What is the brace signal?
- What is the evacuation signal?

Sample Instructor's Notes:

The preflight briefing is often overlooked but is crucial to a safe flight. These items should be covered.

If you don't get a preflight crew briefing, ask for one.

Sample Class Presentation Slide:

Error Management

Few accidents are caused by a single factor. Usually 3-7 factors link together to form an "error chain"

Latent Errors

Equipment Design
Procedures
Checklist

Active Errors

Planning
Execution
"Hurry-Up"

Sample Instructor's Notes:

As stated in slide

Sample Class Presentation Slide:

“Hurry-Up” Errors

Errors that result from an actual or perceived need to hurry or rush

The Big 4

- High workload
- Delays
- Personal agendas (“get-home-itis”)
- Peer/corporate pressures

Sample Instructor’s Notes:

As stated in slide

Sample Class Presentation Slide:

Anticipated Emergencies

- The cockpit crew knows ahead of time that an emergency exists and in all probability the aircraft will have to be evacuated
- You will have time to prepare the cabin and passengers
- **Remember** that the situation may change with a moment’s notice

Most accidents are not anticipated

Sample Instructor’s Notes:

As stated in slide

Gulfstream G500

OPERATING MANUAL SUPPLEMENT

G500-OMS-01

Sample Class Presentation Slide:

Your Procedures

- Remain calm
- Obtain information from PIC
- Ask cockpit to make announcement to the passengers
- **Obtain cabin emergency checklist**

Sample Instructor's Notes:

- Have PIC or SIC make announcement to cabin and give authority to flight attendant
 - Control the passenger's attention
 - Gauge your time. Hand out safety briefing cards.
-

Sample Class Presentation Slide:

Obtain Information From Cockpit

"NTSB"

- **N**ature of emergency
- **T**ime remaining
- **S**pecial circumstances
- **B**race commands

Sample Instructor's Notes:

Acronyms can be used to remember the information we need to obtain from the cockpit to successfully prepare cabin in anticipated emergency.

Sample Class Presentation Slide:

Locate and Review Cabin Emergency Checklist

- Turn cabin lights to bright
- Ask for passengers attention
- Make announcement and give an overview of situation

Sample Instructor's Notes:

Now is the time to take control of the situation. Be firm and authoritative - tell them everything you know and what you will require of them.

Gulfstream G500

OPERATING MANUAL SUPPLEMENT

G500-OMS-01

Sample Class Presentation Slide:

Prepare Cabin

- Reseat Able-Bodied Passengers (ABPs)
- Reserve yourself a seat at an emergency exit (assigned seat if applicable); determine where flashlight and PBE are stored
- Brief ABPs on all available exits (have them repeat instructions back to you)
- Time permitting, brief on operation of emergency exits

Sample Instructor's Notes:

- Who would you select for an ABP? Discuss with class. Mention why we might not select a bodyguard as ABP.
- Reseat sofa passengers (if possible).
- You may have to re-seat a passenger on the jump seat to give yourself a seat in the cabin.
- Reseat pregnant women, lap children, and children in carriers to an aft facing seat (anyone with a compromised physical stature should be aft facing).
- Dogs and their masters are difficult to separate, use an A/C dog harness if possible. If they will remain in the cabin, the best place is under table, aft facing. Do not let them "hold on to" large pets-they won't be able to. Convince them the "for the safety of the pet" the animal should be placed wherever you think is best. (Sandra Bullock's dog was injured on the unanticipated landing accident when thrown from the cabin to the cockpit in 1/2001.)
- For frequent flying dogs, recommend "for the dog's safety" that the owner purchase and familiarize the dog with a safety harness that attaches to a seat belt (designed for car use-Petsmart).

Sample Class Presentation Slide:

Demonstrate PBE Use If Applicable

(Passengers to don at “brace signal” on land emergencies.)

Demonstrate Fastening and Opening Seatbelt

(Have passengers practice.)

Sample Instructor’s Notes:

- Over 30% of passengers involved in a crash on land SURVIVE the accident but are overcome by fumes.
- A/C with passenger PBEs -- these should be donned at the Brace signal to be ready for use during a land evacuation where there is a strong possibility of smoke and fire. If there are no PBEs distribute wet cloth napkins.
- MAKE SURE BELTS ARE TIGHT AND LOW, OVER HIP BONES AND NOT OVER SOFT TISSUE.
- There are common reports of persons reverting to the use of a car seat belt in an emergency. Practicing opening the belt will remind passengers of the operation and remind them of the position of the buckle.

Gulfstream G500

OPERATING MANUAL SUPPLEMENT

G500-OMS-01

Sample Class Presentation Slide:

Demonstrate Brace Positions

(Have passengers practice their positions.)

Sample Instructor's Notes:

Follow **your** aircraft briefing card (brace positions will vary based on aircraft configuration).

Various bracing positions:

FWD FACING SEATS WITHOUT A SHOULDER HARNESS:

- Feet positioned flat on the floor
- Grasp wrists behind knees
- Bend head down

FWD FACING SEATS WITH A SHOULDER HARNESS:

- Feet positioned flat on the floor
- Palms tucked under thighs with palms up
- Press head back into the seat with chin tucked down

AFT FACING SEAT WITHOUT A SHOULDER HARNESS:

Feet positioned flat on the floor

Palms tucked under thighs with palms up

Press head back into the headrest

SIDE FACING SEATS:

- SIDE Facing seats without a shoulder harness:
 - Feet positioned flat on the floor
 - Grasp wrist behind the knees
 - Bend head down

Continued on next page...

Gulfstream G500

OPERATING MANUAL SUPPLEMENT

G500-OMS-01

- SIDE Facing with a shoulder harness:
 - Feet positioned flat on the floor
 - Arms crossed in front (hugging position)
 - Chin tucked

TABLE SEATING:

- FWD facing seats:
 - Track seats in as close as possible to the table
 - Feet positioned flat on the floor
 - Leaning over the table, grasp the other side
 - Head down
 - AFT facing seats:
 - Feet positioned flat on the floor
 - Palms tucked under thighs with palms up
 - Head pressed back into the headrest
- ** WITH SHOULDER HARNESS: be sure that the shoulder harness is secured.
- ** LAP CHILD: should be held by an adult who is secured in their seatbelt and shoulder harness (if applicable) facing AFT. The child should never be in the seatbelt with the adult.

Gulfstream G500

OPERATING MANUAL SUPPLEMENT

G500-OMS-01

Sample Class Presentation Slide:

Special Needs Passengers

- Pregnant, children, or special needs passengers should be in an aft facing seat
- Children in FAA approved car seats should be facing aft (not necessarily in an aft facing seat)
- Consider the best time and method to assist special needs passengers with egress.

Sample Instructor's Notes:

- Assess the best way to egress those passengers with special needs; oversized, infirm, or other physical limitations from safely egressing through the over wing exit.
- **Be prepared to open the main cabin door and all other available exits.**
- The evacuation crewmember must be trained in the procedures for directing passenger flow to the available exits to prevent someone who may not fit through, or may have other personal disabilities which may preclude them from using the elliptical exit, from blocking it so that others may utilize the exit.

Sample Class Presentation Slide:

Secure Cabin And Galley

- Seatbacks upright, stow tables
- Remove dangerous objects from passengers (stow eyeglasses in sock or seat pocket)
- Stow all loose articles; anything loose that could become a missile (laptops, service dishes, flower arrangements, etc...)
- Use trashcan, drawers, etc... for stowage
- Duct tape all sliding doors in galley

Sample Instructor's Notes:

- Remove dangerous objects from person. Place in a galley drawer, trash can, etc. and secure.
 - Eyeglasses should be kept on their person in a safe place so that they will be able to use them for evacuation. Wrap them up in a cloth napkin and stow in sock or in a seat pocket.
-

Sample Class Presentation Slide:

Buddy System

Assign a “buddy” to each passenger and especially to those with special needs. (Don’t forget to give yourself a buddy)

Sample Instructor's Notes:

- Be sure to address special needs passengers and those that are physically unable to egress through the over wing exit. Be prepared to open the main cabin door as needed.
- Make sure you give yourself a buddy!

Gulfstream G500

OPERATING MANUAL SUPPLEMENT

G500-OMS-01

Sample Class Presentation Slide:

Personal Preparation

(Also for passengers if time permits.)

- Void bladder
- Remove jewelry, watches, stockings, and ties
- Change into pants and long sleeve shirt made of natural fibers (denim / cotton)
- Wet hair to remove flammable hair products
- Place additional first-aid kits, flashlights, blankets, etc. inside of a grab bag

Sample Instructor's Notes:

With a small passenger count, all should do this -- time permitting:

1. Void bladder - if ruptured on impact from pressure of seat belt, contents will cause serious internal infections.
2. Jewelry - DO NOT SWALLOW. Do not leave on because if you are injured, your hands may swell and you will lose the finger. Stow it somewhere.
3. Wet hair - to decrease risk of hair catching fire from mousse, gels, spray and other flammable styling products.

Sample Class Presentation Slide:

Final Preparation

- Dim lights
- Inform PIC cabin secure
- Give PIC passenger count and your seat location
- Take your seat and listen for the Brace command
- Begin **Silent Review**

Sample Instructor's Notes:

Do silent review after taking your seat.

Sample Class Presentation Slide:

“BRACE”

Then what?

Listen for the “Evacuation” or “Halt” Command

Sample Instructor’s Notes:

Company specific: (verbal, chimes or silence).

Sample Class Presentation Slide:

Unanticipated Emergencies

70% of aviation accidents are unplanned emergencies.

- Deer / bird strikes
- Runway incursions
- Equipment failure during critical phases of flight

You may only have time to call out

- “Brace”
- “Stay seated, I’m opening an exit.”
- “Stay seated, put your life vest on, I am getting the raft and opening an exit.”

Sample Instructor’s Notes:

Unplanned emergency commands.

Gulfstream G500

OPERATING MANUAL SUPPLEMENT

G500-OMS-01

Sample Class Presentation Slide:

Turbulence

- Turbulence is the leading cause of non-fatal passenger and cabin attendant injuries
- Turbulence is caused by many different factors including abrupt maneuvers and wakes from other aircraft
- Most times turbulence is caused by weather

Sample Instructor's Notes:

- A turbulent atmosphere is one in which air currents vary greatly over very short distances.
- Turbulence is caused by different factors;
 - Abrupt maneuvers
 - Wakes from other aircraft
 - Most times caused by weather
- Weather does not have to be stormy or cloudy to cause turbulence.
- Clear air turbulence can be caused by atmospheric pressure and the absence of air density.
- Thunderstorms also cause turbulence. A thunderstorm can cause turbulence for more than 50 miles around it and thousands of feet above it.
- Flight attendants are 4 times as likely to suffer injury during turbulence as they are frequently moving in the cabin when the seat belt light is illuminated.

Sample Class Presentation Slide:

Clear Air Turbulence

- Higher-altitude phenomenon associated with windshear, particularly between the core of a jetstream and the surrounding air
- Clear air turbulence is most hazardous because it often strikes with no warning

Sample Instructor's Notes:

- Clear air turbulence is a higher-altitude phenomenon associated with wind shear, particularly between the core of a jetstream and the surrounding air.
- According to the FAA's most recent AC-00-30B, it is most common near upper air fronts and the tropopause, the thin layer of air that marks the boundary between the troposphere and the stratosphere and generally has a temperature of -55° C to -65° C.
- Clear air turbulence is most treacherous because it often strikes with no warning.

Sample Class Presentation Slide:

Wake Turbulence

- Vortices of wind are created by the air flow over the wings
- This disrupted airflow can be encountered as far as five miles behind an aircraft

Sample Instructor's Notes:

Unimpeded, vortices descend at 300 to 500 feet per minute for about 30 seconds, ultimately stabilizing between 500 and 900 feet below and, 5NM behind, the generating aircraft.

Gulfstream G500

OPERATING MANUAL SUPPLEMENT

G500-OMS-01

Sample Class Presentation Slide:

Turbulence Tips

- Wear in-flight shoes that give you support and have rubber soles
- If turbulence occurs without warning, sit down, strap in, and hold on
- Check on crew and passengers when it is safe to do so

Do not jeopardize your safety.

Sample Instructor's Notes:

- Check with the Captain during pre-flight to see if turbulence is expected. If so, request updates during the flight.
- If turbulence is expected upon takeoff, ask the Captain what the signal will be to let you know it's safe to get up.
- Wear shoes in-flight that have support and preferably rubber soles.
- If turbulence occurs without warning, sit down, strap in.
- Instruct passengers to fasten their seatbelts. If it's safe to move about the cabin, make a compliance check.
- As soon as it's safe to move about:
- Make sure the entire crew is okay. Communicate to the pilots any damage to the cabin, or medical attention that's administered.
- Check the passengers and provide medical attention if necessary.

Sample Class Presentation Slide:

Evacuation Commands

“Evacuate”

“Easy Victor”

“EZ, EZ”

Sample Instructor’s Notes:

- Company specific
 - Assess conditions, open all exits that are safe to open and evacuate passengers
 - Passengers may panic or sit in state of shock (“shocked to inaction”) and may have to be touched to motivate them to evacuate
 - “Evacuate!” may create panic; be authoritative
-

Sample Class Presentation Slide:

After The Evacuation Command

“Stay Seated”

“Stay Seated, I Am Opening An Exit”

(While you assess conditions and open exits.)

Sample Instructor’s Notes:

- Why?
- Necessary call to permit crew members flight to assess conditions at exit as passengers may impede progress.
- Confusion results from pilot callout to, “Evacuate” vs. “Stay / Remain Seated”.

Gulfstream G500

OPERATING MANUAL SUPPLEMENT

G500-OMS-01

Sample Class Presentation Slide:

Evacuation Commands

“Release / Open Seat Belts”

“Come This Way”

“Come To My Voice / Flashlight”

“Leave Everything”

Sample Instructor’s Notes:

- Use command, “Come to my voice”, or “Come to the flashlight”, if it is dark or there is smoke in the cabin.
 - Be sure to tell passengers to leave everything behind.
-

Sample Class Presentation Slide:

Commands At Window Exit

“Step Up, Step Through”

“Leg, Body, Leg”

“Run Away From The Aircraft”

- Be prepared to redirect other passengers to main cabin door and other over wing exits as required.
- Direct passenger flow to the available exits to prevent someone that may not fit through, or may have other personal disabilities which may preclude them from using the elliptical exit.

Sample Instructor’s Notes:

- Open all viable exits (use ABPs to assist).
- Ask class about their aircraft.
- The evacuation crewmember must be trained in the procedures for directing passenger flow to the available exits to prevent someone who may not fit through, or may have other personal disabilities which may preclude them from using the elliptical exit, from blocking it so that others may utilize the exit.

Sample Class Presentation Slide:

Evacuation

- During an emergency, passengers may become incapacitated, partially or completely
- Evacuate all able bodied passengers first
- Enlist the aid of ABPs or crewmembers to carry or assist those that need help
- Direct passenger flow to the available exits to prevent someone that may not fit through, or may have other personal disabilities which may preclude them from using the elliptical exit

Sample Instructor's Notes:

- Discuss their procedures for removing the passenger or crew member from the seat.
 - The evacuation crewmember must be trained in the procedures for directing passenger flow to the available exits to prevent someone who may not fit through, or may have other personal disabilities which may preclude them from using the elliptical exit, from blocking it so that others may utilize the exit.
-

Sample Class Presentation Slide:

Final Procedures

- Tell first the person out to assist passengers and send away them away from aircraft
- Count people
- Check on cockpit
- Obtain additional items
- If your life is in danger - leave

Sample Instructor's Notes:

- Class discussion
- What to do with injured cockpit members options?

Gulfstream G500

OPERATING MANUAL SUPPLEMENT

G500-OMS-01

Sample Class Presentation Slide:

If Main Cabin Door Is Opened

- Redirect passengers to front door if it is opened
- **Be aware of fire, debris, rescue vehicles, and obstructions outside of the aircraft**

Sample Instructor's Notes:

- Again, it is a much safer exit and fewer injuries may be sustained.
 - The evacuation crewmember must be trained in the procedures for directing passenger flow to the available exits to prevent someone who may not fit through, or may have other personal disabilities which may preclude them from using the elliptical exit, from blocking it so that others may utilize the exit.
-

Sample Class Presentation Slide:

Once You Have Exited the Aircraft

- Assemble passengers at least 100 yards from the aircraft, upwind
- Take a head count, passengers & crewmembers
- Do not permit anyone to smoke
- Do not allow anyone except rescue personnel to re-enter the aircraft
- Treat injuries with available supplies, and according to first aid procedures

Sample Instructor's Notes:

As stated in slide.

Sample Class Presentation Slide:

Rescue Personnel Will Evacuate Injured Passengers

Sample Instructor's Notes:

Emergency personnel are trained to handle these situations.
Concentrate on assisting those outside of the aircraft

Sample Class Presentation Slide:

Procedures If You Are Incapacitated

Be able to direct a passenger to:

- Assess outside conditions
- Ensure water level is below window and door sill before opening
- If not safe, redirect/assist passengers out alternative exit or a break or tear in the fuselage
- Open the emergency exit
- Open the main entry cabin door if required
- Access Life Raft, secure lanyard to aircraft, deploy and inflate raft
- Pull lanyard to bring raft close to aircraft to facilitate direct boarding
- If possible, command passengers to:
 - Jump into water, inflate your life vest, swim to the raft, board raft and help others out of the aircraft

Sample Instructor's Notes:

- Do you know the name of the person (s) at the window exit?
Could you tell them how to get out and help others?
- Can you direct them to the main cabin door and explain to them how to open it?

Gulfstream G500

OPERATING MANUAL SUPPLEMENT

G500-OMS-01

Sample Class Presentation Slide:

Review

1. What does the acronym “NTSB” stand for?
2. In what order do you show your exits to an ABP in an anticipated land emergency?
3. What are you doing in your assigned seat during take off and landing?
4. What should you do if someone is incapable of utilizing the elliptical over-wing exits?

Sample Instructor’s Notes:

1. Nature of Emergency, Time Remaining, Special Circumstances, Brace Commands
2. Over-wing exit, MCD, and baggage door if applicable.
3. Silent review and modified brace position.
4. The evacuation crewmember must be trained in the procedures for directing passenger flow to the available exits to prevent someone who may not fit through, or may have other personal disabilities which may preclude them from using the elliptical exit, from blocking it so that others may utilize the exit.

APPENDIX C
EVACUATION CREWMEMBER EXAM

- 1) What is the first thing that must be done prior to opening any exit?
 - a) Pull down on the red T-handle
 - b) Assess the outside conditions
 - c) Instruct the passengers to “Come this way” while pulling down on the red T-handle
 - d) Instruct the passengers to “Stay seated” while pulling down on the red T-handle

- 2) What would be considered as the primary exit on a Gulfstream G500 for someone determined to be unable to utilize the overwing emergency exits?
 - a) Any available exit
 - b) The baggage compartment door
 - c) The main entry door
 - d) None of the above

- 3) On what side of the fuselage is the main entry door located?
 - a) Fwd A/C left
 - b) Fwd A/C right
 - c) Either of the above
 - d) None of the above

- 4) What would be the first thing that you would need to do when exiting through a window that is located over a divan?
 - a) Pull down on the red T-handle
 - b) Remove the divan seat cushions
 - c) Assess the outside conditions
 - d) None of the above

Gulfstream G500

OPERATING MANUAL SUPPLEMENT

G500-OMS-01

- 5) What are the evacuation commands at a window exit?
 - a) Release/Open Your Seatbelts, Come This Way, Come To My Voice/Flashlight, Leave Everything, Step Up, Step Through, Leg-Body-Leg, Run Away
 - b) Release Your Seatbelts, Come This Way, Come To My Voice/Flashlight, Leave Everything, Step Up, Exit Leg-Head-Leg
 - c) Release Your Seatbelts, Come This Way, Step Up, Step Through, Exit Leg-Body-Leg
 - d) None of the above

- 6) During any emergency evacuation, when should an able passenger exit the A/C?
 - a) These passengers should exit first
 - b) These passengers should exit last
 - c) These passengers should exit after the crewmembers
 - d) None of the above

- 7) If no evacuation command is given from the cockpit, what should you do?
 - a) Wait one full minute before making any decision
 - b) Initiate an evacuation when there is "Fire, Smoke, Water or Structural damage"
 - c) Do nothing unless you hear "EZ, EZ", "Evacuate" or "Easy Victor"
 - d) None of the above

- 8) What is the first thing that you should say once the A/C has come to a complete stop and the PIC gives the Evacuation Command?
 - a) "Evacuate"
 - b) "Come This Way"
 - c) "Stay Seated"
 - d) Both A and B

Gulfstream G500

OPERATING MANUAL SUPPLEMENT

G500-OMS-01

- 9) Once you have accessed the outside conditions, when opening the main entry door on a Gulfstream G500, what is the first thing that must be performed?
- a) Using your left hand, push up on the red ball latch
 - b) Pull back on the red T-handle
 - c) Push up on the red T-handle
 - d) None of the above
- 10) What passenger load requires a third crewmember?
- a) 9 or more passengers
 - b) 10 passengers or more
 - c) 8-10 passengers
 - d) All of the above

Gulfstream G500

OPERATING MANUAL SUPPLEMENT

G500-OMS-01

Answers to exam questions:

- 1) b
- 2) c
- 3) a
- 4) c
- 5) a
- 6) a
- 7) b
- 8) c
- 9) a
- 10) b

APPENDIX D
PASSENGER BRIEFING SCRIPT

Welcome onboard your Gulfstream G500. (pause)

Welcome onboard your Gulfstream G500. (pause)

I would like to take a moment of your time to explain the safety features of your aircraft.

The primary emergency exits are the four over-wing window exits located here (pause)

And here (pause)

The secondary emergency exit is the forward entrance door (pause)

Prior to opening any emergency exit or window exit, assess outside conditions first.

Certain passengers may be unable to exit through the overwing emergency window exits. The alternate exit would be the main entrance door from which you entered the aircraft.

To open an emergency window exit at a divan

Remove the cushions and discard (pause)

Remove the T-handle cover (pause) then pull firmly down on the red T-handle (pause)

And using both window handles, pull the window in and discard.

To exit the aircraft

Step onto the divan and exit leg (pause) body (pause) leg (pause) onto the wing

To open an emergency window exit at a credenza

Remove the T-handle cover (pause) then pull firmly down on the red T-handle (pause)

And using both window handles, pull the window in and discard.

Gulfstream G500

OPERATING MANUAL SUPPLEMENT

G500-OMS-01

To exit the aircraft

Sit on the credenza (*pause*) swing your legs up (*pause*) and out of the window (*pause*)

Roll over onto your stomach (*pause*)

Push your body out of the window (*pause*) and step onto the wing.

To open an emergency window exit at a workstation

Remove the T-handle cover (*pause*) then pull firmly down on the red T-handle (*pause*)

And using both window handles, pull the window in and discard.

To exit the aircraft

Sit on the workstation (*pause*) swing your legs up (*pause*) and out of the window (*pause*)

Roll over onto your stomach (*pause*)

Push your body out of the window (*pause*) and step onto the wing.

To open an emergency window exit at a bed

Remove the T-handle cover (*pause*) then pull firmly down on the red T-handle (*pause*)

And using both window handles, pull the window in and discard.

To exit the aircraft

Step onto the bed and exit leg (*pause*) body (*pause*) leg (*pause*) onto the wing.

To open an emergency window exit at a chair

Remove the T-handle cover (*pause*) then pull firmly down on the red T-handle (*pause*)

And using both window handles, pull the window in and discard.

To exit the aircraft

Step onto the seat and exit leg (*pause*) body (*pause*) leg (*pause*) onto the wing.

To open the emergency window exit from the outside

Push in on the two release buttons (*pause*)

Pull the door open (*pause*)

Reach in and pull up on the red handle (*pause*)

Push in on the top part of the window (*pause*) until it falls in to the aircraft

The aircraft ditching lines are located within the frame of each emergency window exit. (*pause*)

Pull the ditching line out of the window frame (*pause*) and attach it here.

To open the forward entrance door from the inside

Push up on the red ball latch and hold (*pause*).

Push up on the red handle until the door starts to fall out (*pause*)

Let go of both handles as the door opens (*pause*) and step back (*pause*)

Wait until the door is completely down and locked (*pause*) then exit the aircraft

To open the forward entrance door from the outside

Push in on the lower portion of the inner locking handle (*pause*)

Pull out on the exposed edge of the outer locking handle (*pause*) then step to the side (*pause*) as the door falls open

To open the exterior baggage door from the inside

Grasp the door handle and rotate it up (*pause*) and aft

Grab the door grips (*pause*) and pull the door in (*pause*) and up

The interior baggage door must remain closed above 40,000 feet (*pause*) and for take-off and landing. (*pause*)

Access to the baggage compartment is restricted to short periods of time (*pause*) not to exceed 5-minutes. (*pause*)

The baggage door should not be closed (*pause*) while someone is in the baggage compartment.

Gulfstream G500

OPERATING MANUAL SUPPLEMENT

G500-OMS-01

Your Gulfstream G500 is equipped with **emergency escape-path lighting**. *(pause)* Follow the white lights *(pause)* until you reach red lights, *(pause)* which indicate an emergency exit. *(pause)*

Your Gulfstream G500 is equipped with **emergency escape-path lighting**. *(pause)* Follow the white lights *(pause)* until you reach red lights, *(pause)* which indicate an emergency exit. *(pause)*

(Seat belt 1)

To fasten your seat belt *(pause)* place the flat metal end into the buckle *(pause)*

Reach behind your shoulder and pull the shoulder harness across your chest and fasten to the seatbelt button *(pause)*

To tighten your seatbelt *(pause)* pull on the strap *(pause)*

To unfasten your seatbelt *(pause)* release the shoulder harness *(pause)* and lift up on the top portion of the buckle.

(Seat belt 2)

To fasten your seat belt *(pause)* place the flat metal end into the buckle *(pause)* Reach behind your shoulder and pull the shoulder harness across your chest and fasten to the seatbelt button *(pause)*

To tighten your seat belt *(pause)* pull on the strap *(pause)*

To unfasten your seatbelt *(pause)* release the shoulder harness *(pause)* and push in *(pause)* on the seat belt release

(Seat belt at a divan)

To fasten your seat belt on a divan *(pause)* place the flat metal end into the buckle *(pause)*

Pull the shoulder harness up *(pause)* and over *(pause)* from behind the seat back cushion and fasten on to the seat belt button *(pause)*

To tighten your seat belt *(pause)* pull on the strap *(pause)*

To unfasten your seatbelt *(pause)* release the shoulder harness *(pause)* and push in *(pause)* on the seat belt release

Gulfstream G500

OPERATING MANUAL SUPPLEMENT

G500-OMS-01

Should cabin pressure change suddenly (*pause*) a compartment above your head will open automatically (*pause*) and an oxygen mask will be within your reach (*pause*)

Extinguish all smoking materials (*pause*)

Pull the mask towards you to start the flow of oxygen (*pause*)

Place it over your nose and mouth (*pause*) then place the elastic band over your head (*pause*)

To tighten (*pause*) pull on the elastic straps on either side (*pause*)

Make certain your seatbelt is securely fastened (*pause*)

Even though oxygen is flowing (*pause*) the bag on the mask will not fully inflate (*pause*)

Put on your own mask before attempting to assist anyone else (*pause*) and continue to use until otherwise instructed by a crewmember.

Your life vest is located in the seat base of your chair (*pause*)

Your life vest is located in the footrest of your chair (*pause*)

Your life vest is located in this compartment (*pause*) underneath the divan (*pause*)

Your life vest is located within the armrest of your chair (*pause*)

Your life vest is located under your seat (*pause*)

(With a cover)

Remove the vest from the compartment (*pause*) and remove the protective cover (*pause*)

Remove the vest from the plastic bag (*pause*) by pulling on the pull-tab (*pause*)

Unfold the life vest and place it over your head (*pause*)

Place the strap around your waist (*pause*) and secure with the clip (*pause*)

Tighten the strap by pulling on the yellow end (*pause*)

Inflate your life vest after you have exited the aircraft by pulling down on the red pull-tabs located here. (*pause*)

Gulfstream G500

OPERATING MANUAL SUPPLEMENT

G500-OMS-01

To manually inflate your life vest blow into the tubes located on either side of the life vest (*pause*)

A water-activated light is located here (*pause*)

A whistle is located here (*pause*)

(Without a cover)

Remove the vest from the compartment (*pause*)

Remove the vest from the plastic bag (*pause*) by pulling on the pull-tab (*pause*)

Unfold the life vest and place it over your head (*pause*)

Place the strap around your waist (*pause*) and secure with the clip (*pause*)

Tighten the strap by pulling on the yellow end (*pause*)

Inflate your life vest after you have exited the aircraft by pulling down on the red pull-tabs located here. (*pause*)

To manually inflate your life vest blow into the tubes located on either side of the life vest (*pause*)

A water-activated light is located here (*pause*)

A whistle is located here.

There are life rafts onboard your aircraft stowed here (*pause*)

And here (*pause*)

(With a cover)

Remove the life raft from the compartment (*pause*)

Remove the life raft cover (*pause*) and move the life raft (*pause*) and survival equipment (*pause*) to a window exit (*pause*)

Fasten the seatbelt (*pause*)

Then remove the mooring line from under the flap (*pause*) and securely fasten it to the seatbelt (*pause*)

Open and pull the emergency window exit in, (*pause*) and discard. (*pause*) Place the life raft through the open window exit

Gulfstream G500

OPERATING MANUAL SUPPLEMENT

G500-OMS-01

(Without a cover)

Remove the life raft from the compartment (*pause*) and move the life raft (*pause*) and survival equipment (*pause*) to a window exit (*pause*)

Fasten the seatbelt (*pause*)

Then remove the mooring line from under the flap (*pause*) and securely fasten it to the seatbelt (*pause*)

Open and pull the emergency window exit in, (*pause*) and discard. (*pause*)

Place the life raft through the open window exit

(With release tabs)

Pull down on the release tabs.

There are fire extinguishers onboard this aircraft (*pause*) located here (*pause*)

There are portable breathing devices onboard your aircraft (*pause*) located here (*pause*)

There is a therapeutic oxygen outlet located here (*pause*)

There are therapeutic oxygen outlets located here (*pause*)

There is a smoke hood located here (*pause*)

There are smoke hoods located here (*pause*)

There is a First Aid kit located here (*pause*)

There are First Aid kits located here (*pause*)

There is an Emergency Medical kit located here (*pause*)

There is an Automatic External Defibrillator located here (*pause*)

There is a Crash Axe located here (*pause*)

There are flashlights located here (*pause*)

Federal Aviation Regulations require your compliance (*pause*) with the **lighted** (*pause*) **no smoking and fasten seat belt signs** (*pause*)

It is also a Federal offense (*pause*) to tamper with (*pause*) or disable (*pause*) the smoke detectors onboard. (*pause*)

Gulfstream G500

OPERATING MANUAL SUPPLEMENT

G500-OMS-01

This page intentionally left blank.

APPENDIX D
TRAINING VERIFICATION

INITIAL TRAINING VERIFICATION

G500 Evacuation Crew Member Training

Date
Completed

1. Completed **Evacuation Crewmember Training Course** in accordance with the requirements of this document as outlined in the **Appendix A** curriculum and the **Appendix B** courseware. _____

2. Completed **Specific Interior Configuration Training** as specified in the **Specific Interior Configuration Training** section. _____

Evacuation Crewmember

(sign)

Director of Aviation

(sign)

Gulfstream G500

OPERATING MANUAL SUPPLEMENT

G500-OMS-01

This page intentionally left blank.

RECURRENT TRAINING VERIFICATION

G500 Evacuation Crew Member Training

Date
Completed

1. Completed the **Evacuation Crewmember Exam** contained in **Appendix C**. _____
2. Completed **Specific Interior Configuration Training** as specified in the **Specific Interior Configuration Training** section. _____
3. Completed the **Emergency Egress Drills** appropriate to the recurrent training as specified in the **Passenger Flow** section. _____

NOTE: This item required every 24 months.

Evacuation Crewmember _____
(sign)

Director of Aviation _____
(sign)

Gulfstream G500

OPERATING MANUAL SUPPLEMENT

G500-OMS-01

This page intentionally left blank.